

Deluxe Cat Home 3 Levels

Model: # 7501

Instructions online at www.prevuepet.com

read first REVIEW BEFORE ASSEMBLY

- No tools are required for assembly
- One person will be able to assemble this premium cat home
- For best results, follow steps in order

For assistance or replacement parts, please contact Prevue Pet Products:
PHONE 1 (312) 243-3624
ONLINE www.prevuepet.com
EMAIL customerservice@prevuepet.com

1 To assemble the **BASE**, you will need these pieces:

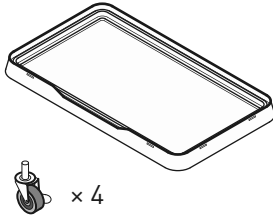

Turn the base over and insert rolling casters.

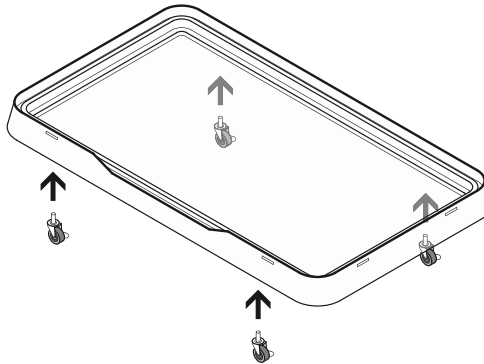

TIP:

When OFF is up, casters ROLL

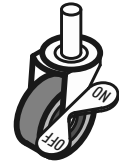

When ON is up, casters LOCK

2 To assemble the **LOWER SECTION**, you will need these pieces:

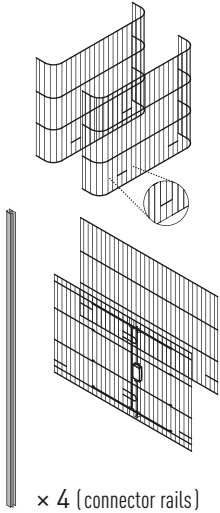

Locate the four panels with short horizontal bars along the lower edge. Stand the side panel into the base.

Hold the back panel in place. Note: Orient the panel with the thick horizontal wires to the cage exterior. Thinner vertical wires face the cage interior.

Slide a connector rail down over the two-panel seam [see Fig. 2.1 and Fig. 2.2] until the tops are flush. Note: The flat surface of the connector rail faces the exterior. The rounded surface faces the interior.

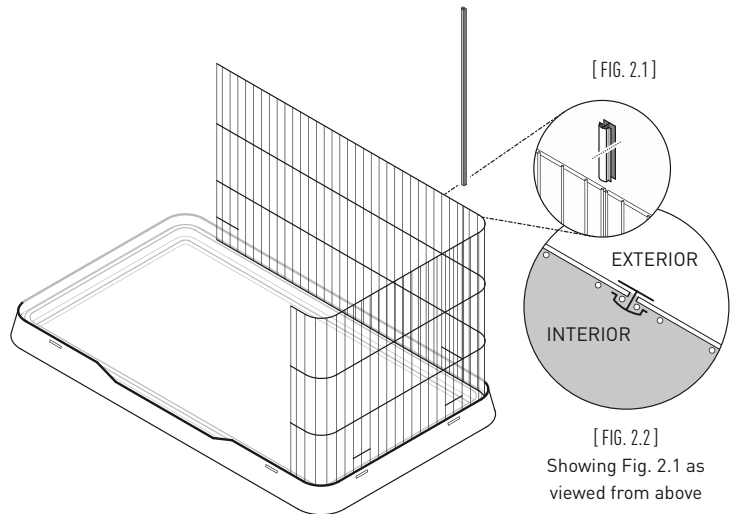

Continue around the cage, adding the side and front panels and attaching panels with the connector rails.

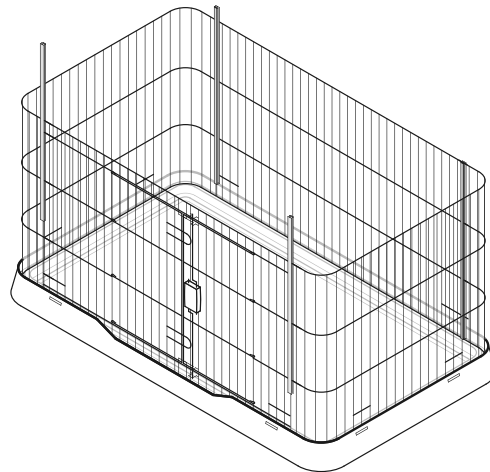

3 To assemble the **MIDDLE & UPPER SECTIONS**, you will need two sets of these pieces:

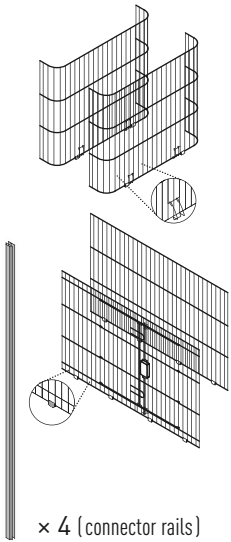

The remaining panels all feature solid metal guide tabs along the bottom wire and wire clips on the side panels [see Fig. 3.1].

Start with the side panel. Use the guide tabs to align it directly over the lower panel, then clip the panels together by pressing down at the middle (apex) of the wire clip [see Fig. 3.2].

Add the back panel—thick horizontal wires to the exterior, aligning directly over the lower panel with the guide tabs—and slide a connector rail down over the two-panel seam.

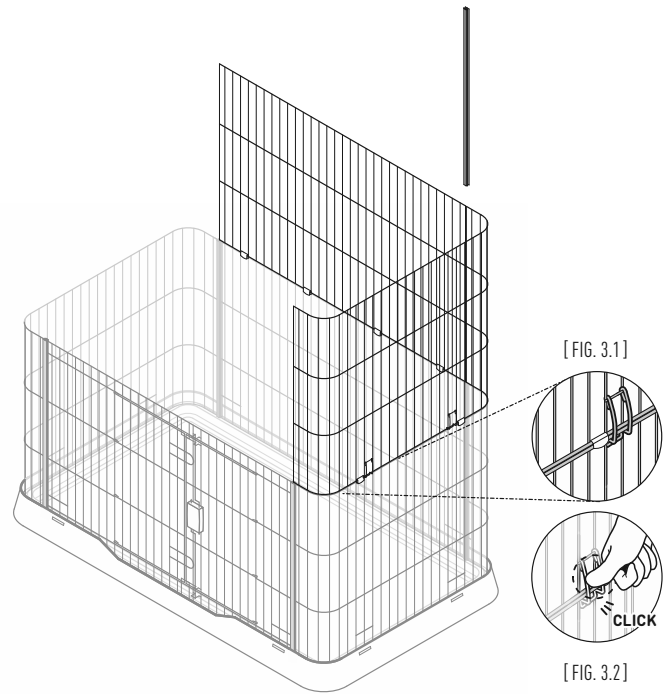

Continue around the cage, adding the side and front panels and attaching panels with the connector rails.

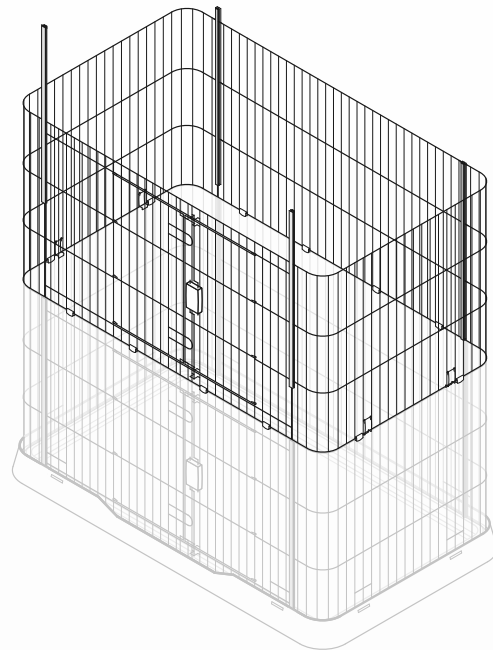

4 To assemble the **ROOF**, you will need this piece:

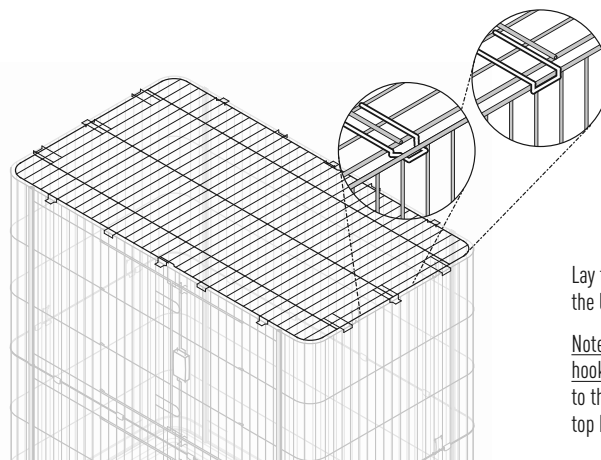
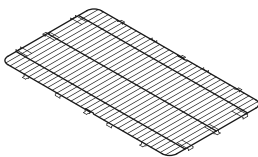

Lay the roof panel over the top and weave the loops over and under along the top edge.

Note: From the side, the center loop will hook UNDER the horizontal wire. The loops to the left and right will hook OVER the top horizontal wire.

5

To complete the cage assembly, you will need these pieces:



× 4



× 4



× 8

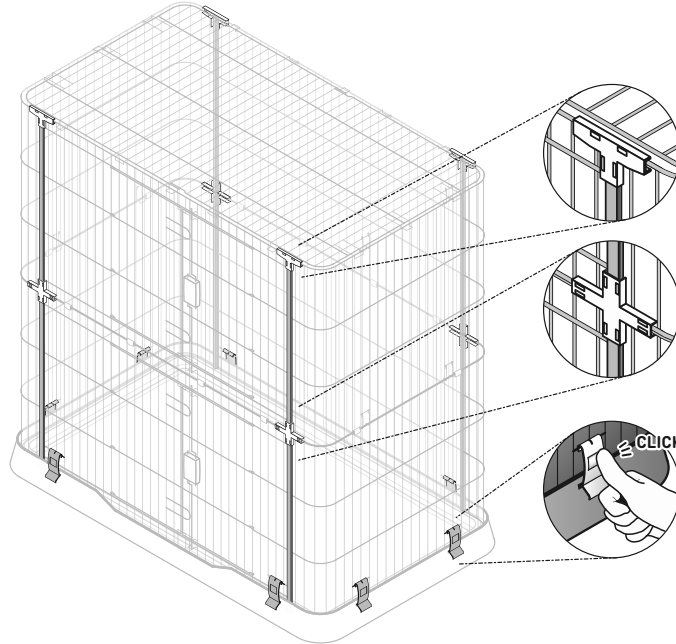

To solidify the entire cage, press a connector onto each panel intersection until it clicks and all surfaces are flush.

"T" clips connect the intersections along the front and back top edge.

NOTE: "T" clips do not connect with the roof panel.

"+" clips connect the intersection of panels on the front and back.

Base clips connect the cage to the base. Hook the "claw" end of the clip onto the short horizontal wire. Press your thumb into the dimple of the clip and press down until it clicks into the slot on the cage base.

6

To add the **PLATFORMS**, you will need these pieces:

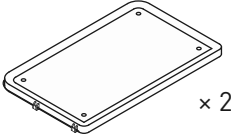

× 2

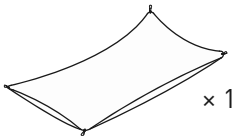

× 1

Hammocks and platforms may be placed at different levels, but for best results, add them to the interior at the positions illustrated here.

For solid platforms, make sure they clip fully into place on the cage wires for maximum stability.

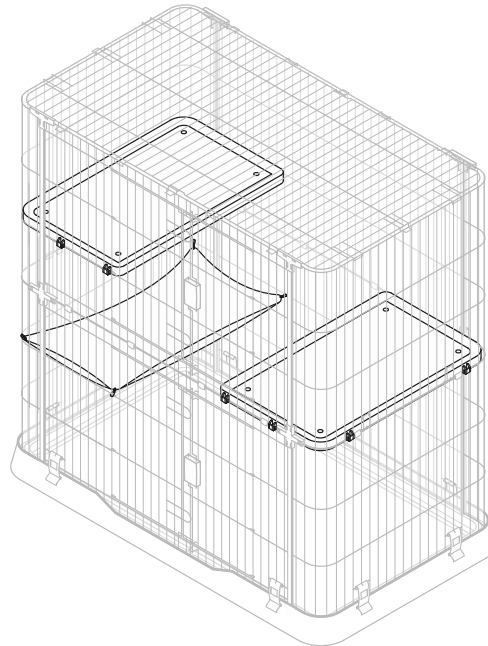

★ Your cage is now fully assembled and ready for use.

