

CORALIFE®

SUPER SKIMMERS

Instructions

Please read these instructions in their entirety before attempting to use this product.



The pumps used with the Coralife 65G, 125G and 220G Super Skimmers are listed by Underwriters Laboratories to ensure that they meet the stringent U.S. and Canadian safety requirements.

Coralife®

A product of Central Aquatics
(Division of Central Garden & Pet)

Franklin, WI 53132

888.255.4527 coralifeproducts.com

Coralife® is a registered trademark of Central Garden & Pet
© 2010 Central Garden & Pet



IMPORTANT SAFETY INSTRUCTIONS

READ AND FOLLOW ALL SAFETY INSTRUCTIONS

CAUTION

To guard against injury, basic safety precautions should be observed when operating the unit.

WARNING

1. Never connect the Coralife Super Skimmer to any power source while hands are wet.
2. Always unplug the unit from outlet or power source before installing, replacing parts or doing product maintenance.
3. Never allow pump to run dry. Always keep pump submerged during operation. Failure to keep pump submerged while in use may damage the unit and/or cause unit failure.
4. Always leave a drip-loop in the pump cord to prevent water from running down the length of the cord and reaching the power source or outlet.
5. For added safety, the pump should be plugged into a grounded three-prong receptacle controlled by a GFI (Ground Fault Interrupter) circuit breaker.
6. Make sure that the Super Skimmer is securely installed before operating.

PRE-INSTALLATION SETUP

NOTE: Prepare at least 5 gallons of "make-up water" to replace water used by the Super Skimmer. (P2)

HANG-ON TANK MOUNT PLACEMENT

1. Allow a minimum 8" clearance between the aquarium and the wall.
 - NOTE:** Hang-on tank mounting bracket for up to 1.125" tank mouldings.
2. Ensure that there is adequate unobstructed space for the pump inside the aquarium (9"L x 4"W x 5"H).

SUMP HOOK-UP PLACEMENT

1. Verify that there is adequate space for the super skimmer in/or outside of the sump (12"L x 10"W).
2. Allow a minimum 1" clearance between the underside of the stand and the top of the skimmer. **Make sure there is enough space to remove/slide the collection cup out of the sump.**

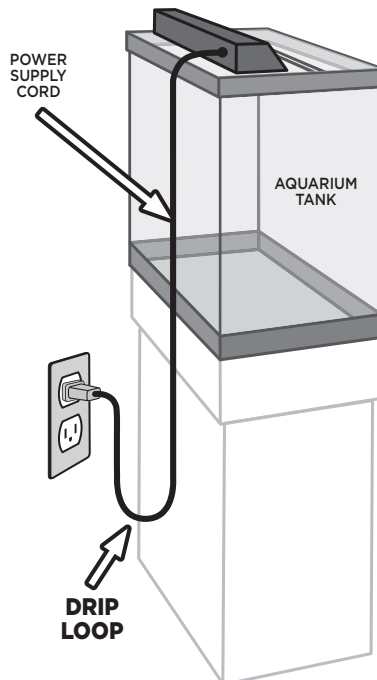

PARTS DIAGRAM

1.0

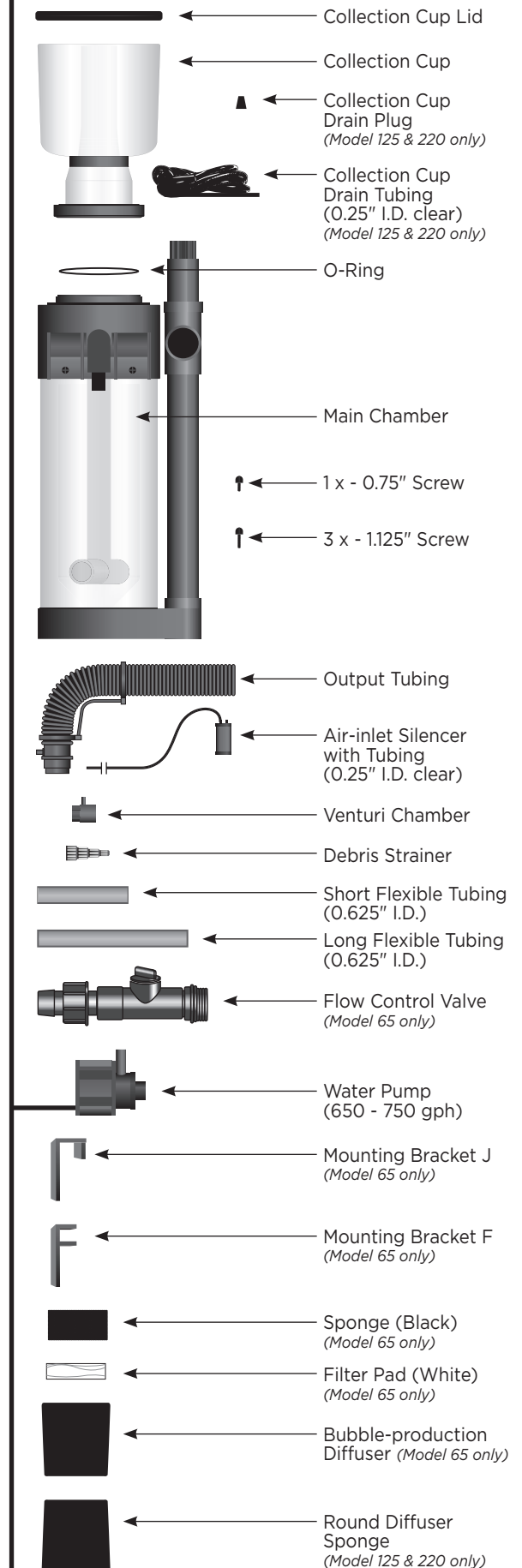

INSTALLATION SETUP

BUBBLE-PRODUCTION DIFFUSER SETUP (Model 65 only)

1. Load filter pad (white) into bubble-production diffuser. (2.0)
2. Place sponge (black) on top of filter pad (white).
3. Insert mounting bracket into the slot located at the back of the bubble-production diffuser.

NOTE: Identify the type of molding on aquarium or sump and select the correct mounting bracket. (2.1)

COLLECTION CUP SETUP (Model 65 only)

1. Place o-ring into o-ring groove in top opening of main chamber.
2. Align collection cup threaded ring with the top opening on main chamber.
3. Twist collection cup threaded ring clockwise and tighten. Make sure that the connection is secure between both the collection cup and main chamber.

COLLECTION CUP SETUP (Model 125 & 220 only)

1. Attach the collection cup lid to collection cup. (2.2)
2. Attach collection cup drain plug onto collection cup drain or attach collection cup tubing for an optional drain line.

NOTE: Collection cup drain line prevents overflow when attached to a large capacity receptacle.

Collection Cup Drain Plug Attachment

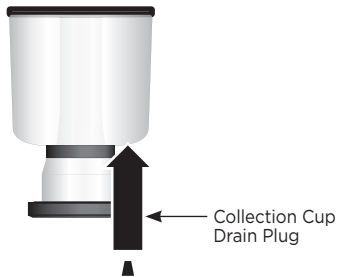

Collection Cup Drain Tubing Attachment



3. Place o-ring into o-ring groove in top opening of main chamber.
4. Align collection cup threaded ring with the top opening on main chamber.
5. Twist collection cup threaded ring clockwise and tighten. Make sure that the connection is secure between both the collection cup and main chamber.

SIDE VIEW (Model 65 only) 2.0

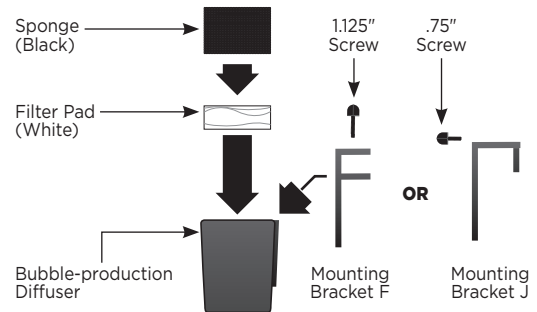

SIDE VIEW 2.1

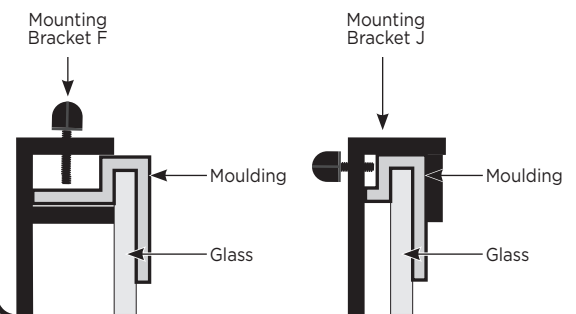

SIDE DETAIL 2.2

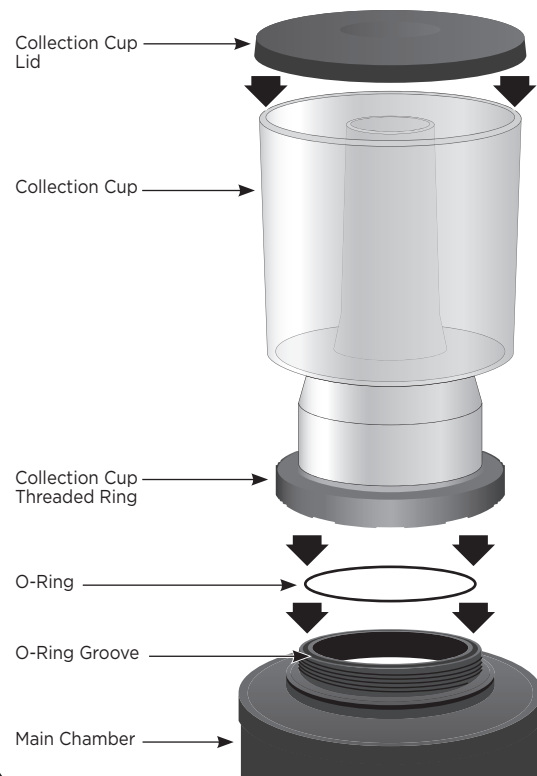

INSTALLATION SETUP

HANG-ON MOUNT INSTALLATION SETUP

NOTE: Saltwater may need to be added to the aquarium to replace water used by the super skimmer.

1. Locate desired area to place skimmer.
2. Attach short flexible tubing onto chamber intake. (3.0)
3. Attach water pump (with Flow Control Valve on Model 65) to flexible tubing.

NOTE: Make sure all tubing connections are secured.

4. Hang main chamber skimmer bracket at desired location on aquarium.

WARNING: Do not submerge in water or obstruct airway passage through air-inlet silencer.

5. Attach output tubing onto water output with vent hole facing up. (3.1)
6. Attach bubble-production diffuser onto aquarium. (3.2)

NOTE: Adjust bubble-production diffuser mounting bracket. Top of bubble-production diffuser must be .25" min. above water line.

7. Insert the output tubing into bubble-production diffuser sponge (black). (3.2)

NOTE: Trim output tubing or adjust bubble-production diffuser height to allow a 1" min. space inside the sponge (black) to prevent micro-bubbles.

8. Tighten screws on main chamber skimmer bracket and bubble-production diffuser bracket.

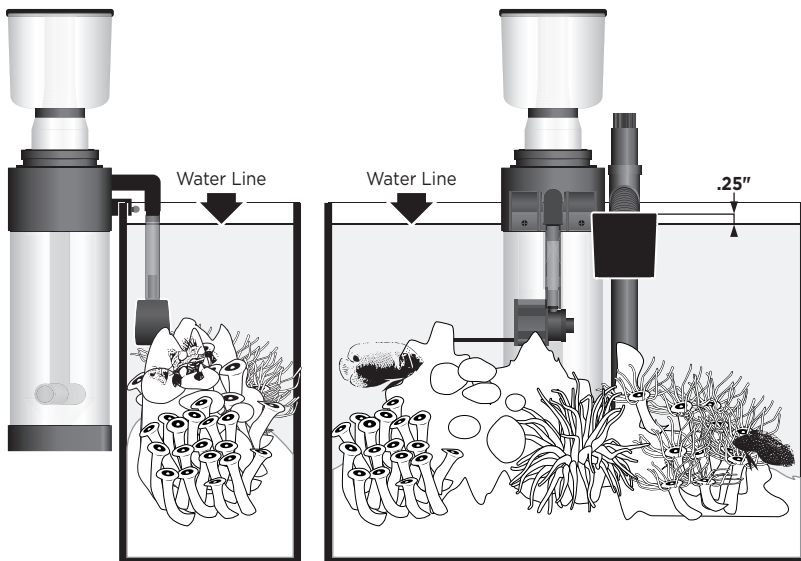
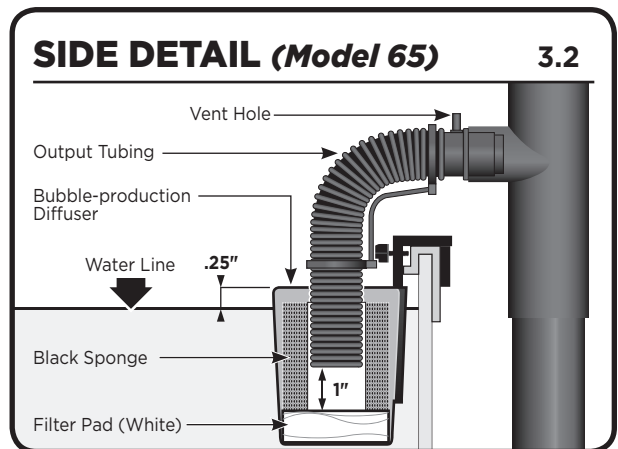
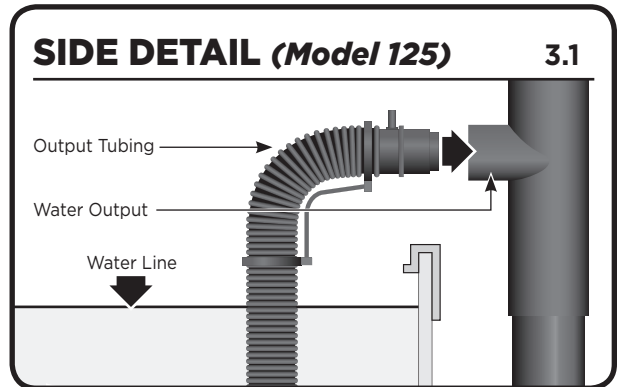
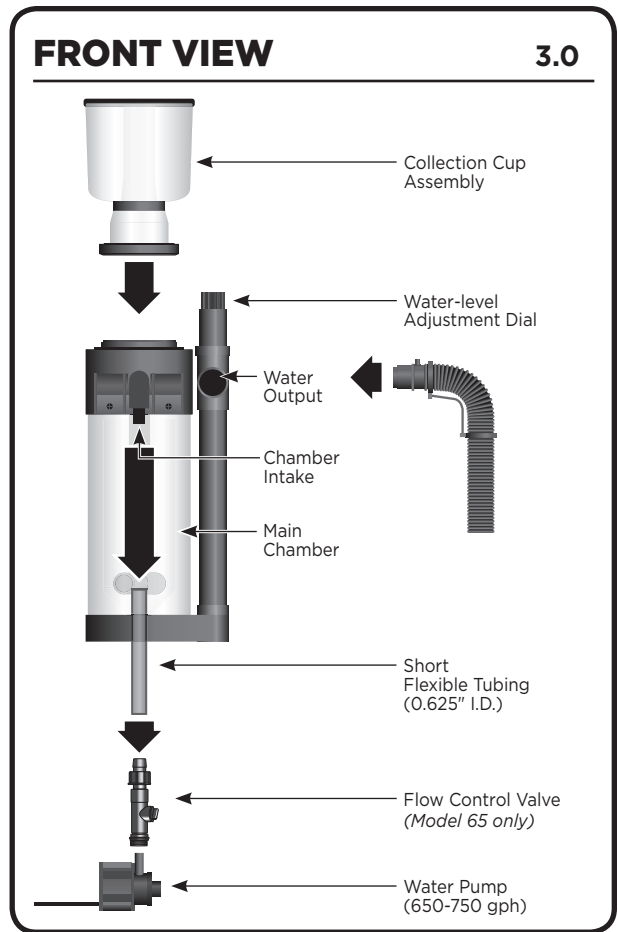

INSTALLATION SETUP

IN-SUMP INSTALLATION SETUP

NOTE: Saltwater may need to be added to the aquarium to replace water used by the Super Skimmer.

1. Locate desired area to place skimmer.
2. Attach long flexible tubing onto chamber intake. (4.0)
3. Attach water pump (650 - 750 gph) to flexible tubing.
NOTE: Make sure all tubing connections are secured.
4. Place Super Skimmer inside/outside sump at desired location.

NOTE: Add saltwater to skimmer to prevent from floating in the sump.

WARNING: Do not submerge in water or obstruct airway passage through air-inlet silencer.

5. Attach output tubing onto water output with vent hole facing up. (4.1)
6. Place round diffuser sponge into sump. (4.2)

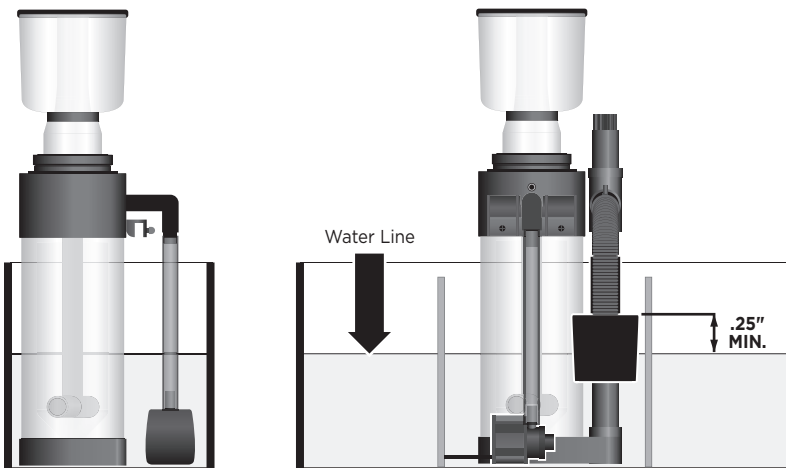
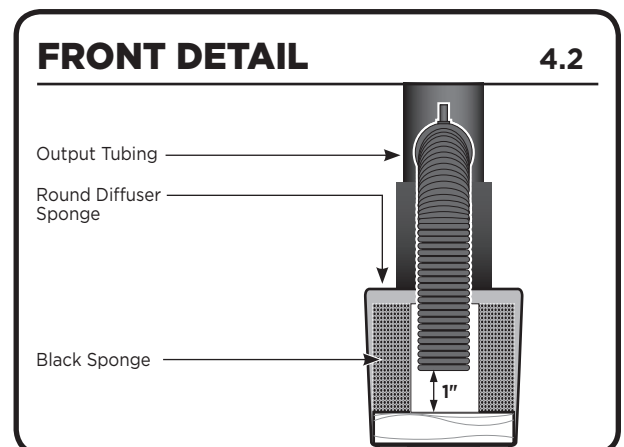
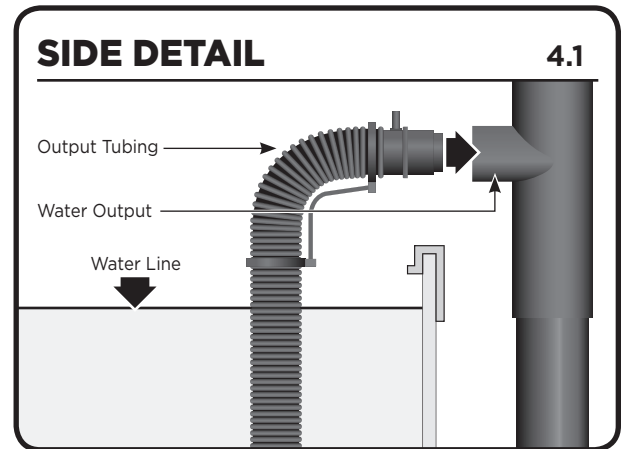
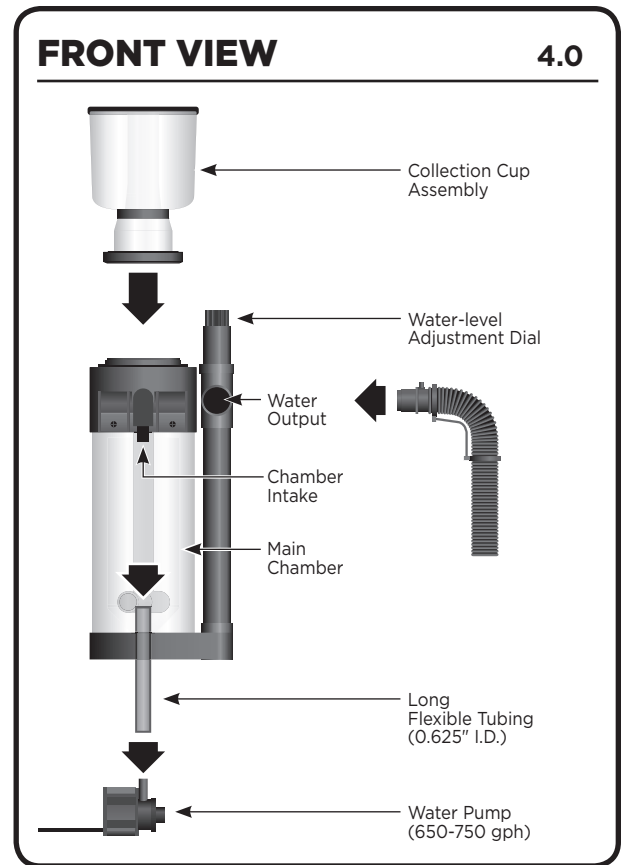

OPERATION

PRE-OPERATION

1. Make sure that all tubing connections are tightly secured.
2. Verify that collection cup and lid are tightly fastened and sealed to the main chamber.
3. Make sure that the air-inlet silencer is above the water.
NOTE: Do not obstruct air flow into air-inlet silencer.
4. Check water-level adjustment dial and make sure it is in the open position. (5.0)

INITIAL OPERATION

1. Plug water pump (650 - 750 gph) into an outlet or power source.
NOTE: Inspect connections for leaks and make sure that the water is flowing through the unit.
2. Adjust water-level adjustment dial so that the micro-bubbles are below the collection cup cone. **Let the pump run for 24 - 72 hours to "break-in" the unit. (5.1)** Use flow control valve for coarse water level adjustment with Model 65. Use water level adjustment dial for fine adjustment.
NOTE: Initial operation of protein skimmer may produce excess bubbles and waste. Allow collection cup to fill-up and discard waste-water until production decreases.

OPERATION

1. Turn water-level adjustment dial to raise water level within the main chamber and cone to desired skimming operation.

DRY SKIMMING OPERATION (5.2)

1. Adjust micro-bubbles to .25" - .75" high inside collection cup cone.
NOTE: Dry skimming will produce a dense foam layer which rises to the top of the cone where it collects until the dry foam overflows into the collection cup.

RESULTS:

1. Dry foam (froth)
2. Dark, concentrated waste material (Less Volume)

WET SKIMMING OPERATION (5.3)

1. Adjust micro-bubbles to .75" - 3" high inside collection cup cone.
NOTE: Wet skimming will produce a thin bubble layer which rises to the collection cup lid where it bursts and slides down the collection cup as wet wastewater.

RESULTS:

1. Wet foam
2. Light, diluted waste material (More Volume)

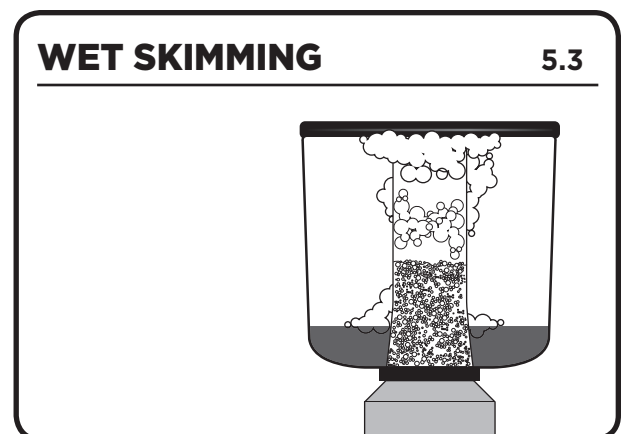
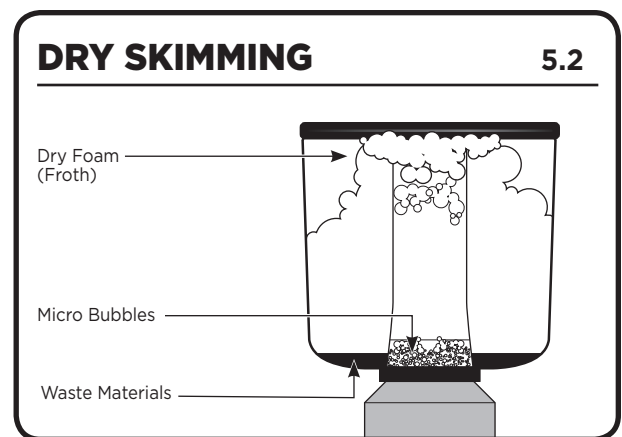
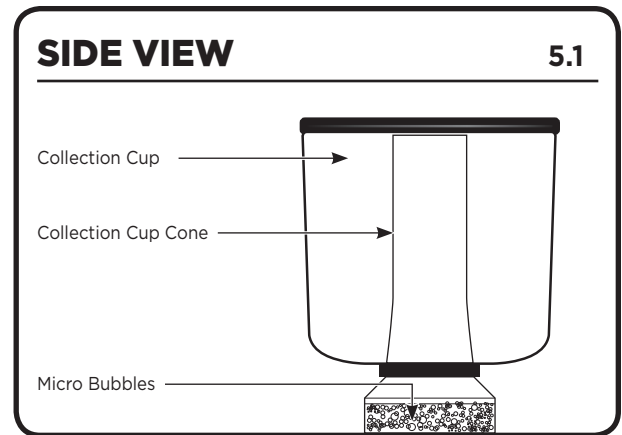
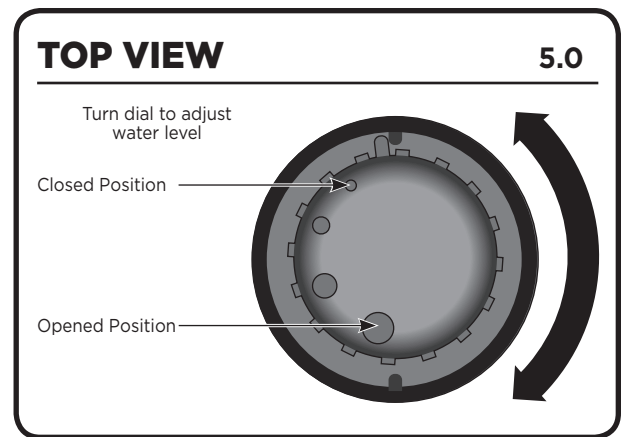

MAINTENANCE

MAINTENANCE

SAFETY: Always disconnect needle-wheel pump from power supply before removing collection cup or cleaning unit.

WARNING: Only clean with warm fresh water. Do not use any type of chemical cleaning agent to clean the skimmer. These include, but not limited to, soap, detergents, alcohol, glass cleaners, polishers, ammonia, etc.

1. To operate efficiently, the Super Skimmer must be in use 24 hours a day.

DAILY MAINTENANCE

1. Make sure all connections are secure.
2. Observe to see if skimmer is functioning properly and producing waste material.

NOTE: Skimmer may need to be adjusted accordingly due to variables in water quality and fluctuations.

3. Check to see if the collection cup is full and empty waste material.
4. Check water outlet vent hole to make sure it is clear of dirt and debris.
5. Check air-inlet silencer and make sure it is clean and free of dirt and debris.

WEEKLY MAINTENANCE

1. Clean the collection cup and neck of organic build up.
2. Clean or replace the sponge and filter from the bubble production diffuser.

MONTHLY MAINTENANCE

1. Clean water pump.

NOTE: Make sure to follow manufacturer instructions for component's proper installation, operation and maintenance.

TROUBLESHOOTING

NOTE: Variables that affect skimming to produce dry or wet foam are:

- a. New Fish or Invertebrates
 - b. Frequent Feeding
 - c. Change in Water Chemistry
 - d. Supplements and Medication
 - e. Water Quality
 - f. Water Fluctuations/Evaporation
 - g. Addition of "Make-up" Water
 - h. Water Changes
 - i. Maintenance
 - j. Inserting hands in the tank
1. No microbubbles produced inside the skimmer.
 - a. The air-inlet silencer is clogged.
 - b. Pump is not plugged in.
 2. No foam produced inside collection cup.
 - a. Adjust water level inside the skimmer.
 - b. New skimmer may take up to 72 hrs. to adjust properly to aquarium system.
 3. Water pump is not working.
 - a. Check to make sure power is supplied.

NOTE: Make sure to follow manufacturer instructions for component's proper installation, operation and maintenance.
 4. Skimmer water level fluctuates (pulses).
 - a. The output tubing air vent hole is clogged causing the skimmer to create a siphon.
 - b. Output tubing is too deep inside of bubble trap. Cut output tubing and allow a 1" space inside the sponge (black).
 5. Water is rapidly overflowing into collection cup.
 - a. Reduce water level in the skimmer. Water level may be too high.
 - b. Make sure water is flowing through output tubing. Bubble production diffuser may be clogged, blocking water flow.
 - c. Changes in water chemistry. Readjust water-level adjustment dial to lower water level in skimmer.
 - d. Output tubing is pushed against white filter pad in bubble-production diffuser. Allow 1" of space between bottom of output tubing and filter pad (white).

12 Month Limited Warranty

WHAT THE WARRANTY COVERS:

Central Aquatics (Company) warrants this Coralife product (see Exclusions below) to the original purchaser against defective material and workmanship that occurs during normal in-home use for 12 months from date of purchase. Company will, at Company's option, either repair or replace same without charge (but no cash refunds will be made). This warranty is limited to replacement or repair of product only and does not cover loss of aquarium life, personal injury, property loss, or damage arising from the use of the product. You must retain original proof of purchase to validate this warranty.

EXCLUSIONS:

1. Damage resulting from accident, misuse, abuse, lack of reasonable care, subjecting the product to any but the specified electrical service, other than the normal and ordinary use of the product, subjecting the product to abnormal working conditions or any other failure not resulting from defects in materials or workmanship.
2. Damage resulting from modification, tampering with or attempted repair by anyone other than the Company.
3. Transfer of product to someone other than the original consumer or purchaser.

WHAT YOU MUST DO TO ENFORCE WARRANTY:

Contact the Company by telephone:

888-255-4527

Or contact the Company by writing:

Central Aquatics

5401 West Oakwood Park Drive, Franklin, WI 53132

Attn.: Warranty

You must pay any postage, shipping charges, insurance costs and other expenses to return the product along with the original cash register receipt to Central Aquatics. However, if the necessary repairs are covered by the warranty, Company will pay the return shipping charges to any destination within the United States or Canada.

LIMITATION OF IMPLIED WARRANTIES AND EXCLUSION OF CERTAIN DAMAGES: THE COMPANY DISCLAIMS LIABILITY FOR INCIDENTAL AND CONSEQUENTIAL DAMAGES FOR BREACH OF ANY EXPRESS OR IMPLIED WARRANTY, INCLUDING ANY IMPLIED WARRANTY OF MERCHANTABILITY, WITH RESPECT TO THIS PRODUCT. THIS WRITING CONSTITUTES THE ENTIRE AGREEMENT OF THE PARTIES WITH RESPECT TO THE SUBJECT MATTER HEREOF; NO WAIVER OR AMENDMENT SHALL BE VALID UNLESS IN WRITING SIGNED BY THE COMPANY.

Some states do not allow the exclusion or limitation of consequential damages, so the above limitation or exclusion may not apply to you.