



protect. teach. love.®

Drinkwell
SEDONA
Pet Fountain

Operating Guide

Model Number
PWW00-15417

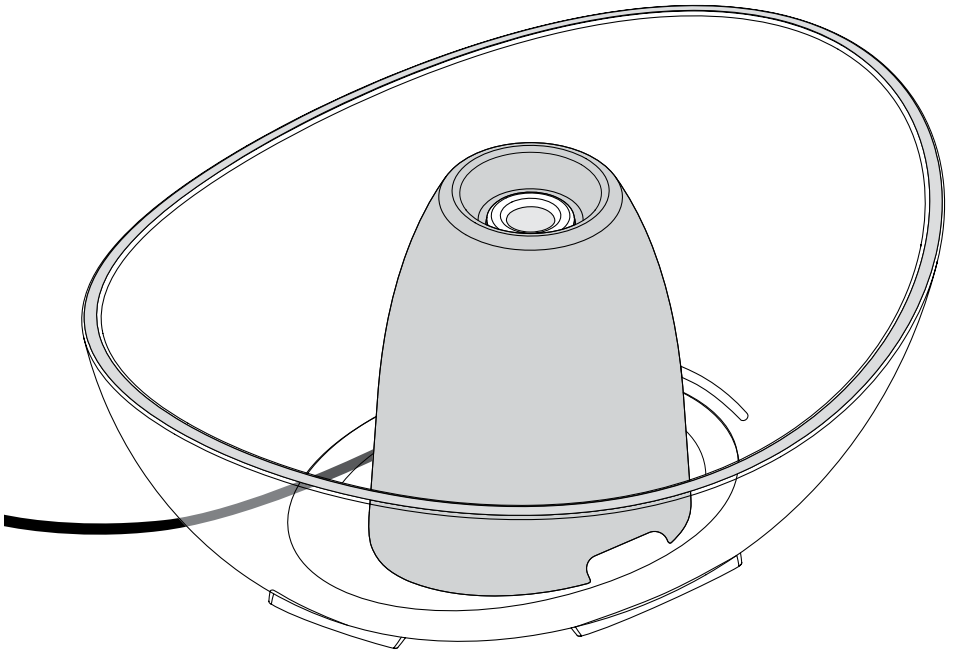

PLEASE READ THIS ENTIRE GUIDE BEFORE BEGINNING

IMPORTANT SAFETY INFORMATION

Explanation of Attention Words and Symbols used in this guide

 This is the safety alert symbol. It is used to alert you to potential personal injury hazards. Obey all safety messages that follow this symbol to avoid possible injury or death.

WARNING WARNING indicates a hazardous situation which, if not avoided, could result in death or serious injury.

CAUTION CAUTION, used without the safety alert symbol, indicates a hazardous situation which, if not avoided, could result in harm to your pet.

NOTICE NOTICE is used to address safe use practices not related to personal injury.

WARNING

When using electrical appliances, basic safety precautions should always be followed to reduce the risk of fire, electric shock and/or injury to persons, including the following: To reduce the risk of injury, close supervision is necessary when an appliance is used by or near children.

- To protect against electric shock, do not place electrical power cord or plug in water or other liquids.
- Do not use outdoors. Do not run dry. For indoor household use only.
- Do not pull on the electrical power cord to remove the plug from the electrical outlet.
- To unplug, grasp the plug, not the electrical power cord.
- Do not operate any appliance if it has a damaged electrical power cord or plug, or if it is malfunctioning or has been damaged. Call Customer Care Center immediately for further instructions.
- For a portable appliance - To reduce the risk of electric shock, do not place or store an appliance where it can fall or be pulled into a bathtub or sink.
- Always unplug any appliance when not in use, before putting on or taking off parts, and before cleaning.
- Do not use an appliance for anything other than its intended use.
- If the plug of this device gets wet, turn off the electricity to that electrical outlet. Do not attempt to unplug.
- Examine this appliance after installation. Do not plug into electrical outlet if there is water on the electrical power cord or plug.
- Always unplug any appliance when not in use, before putting on or taking off parts, and before cleaning. Never pull on the electrical power cord to remove the plug from the wall outlet.

CAUTION

- Do not allow pets to chew on or swallow any parts. If you are concerned about the power cord, purchase a cord conduit (a hard plastic protector) at any hardware store.

- The plastic fountain parts are BPA-FREE. However, some animals have been known to be sensitive to plastic food and water containers. If your animal shows signs of an allergic reaction to the plastic, please discontinue use until you have consulted with your veterinarian.

NOTICE

- The fountain is intended to run continuously (always plugged into an electrical outlet), as long as the water level is maintained and the fountain is cleaned regularly. Be sure to check the fountain regularly to help prevent damage to the pump, as the water may get consumed or evaporate causing the pump to run dry.
- Do not attempt repairs on the pump.
- To avoid the possibility of the plug or electrical outlet getting wet, the electrical outlet should always be above the level of the fountain.
- If an extension cord is necessary, an extension cord with a proper rating should be used.
- The electrical use of this appliance is 2.5 watts.
- The use of attachments not recommended or sold by the manufacturer may cause an unsafe condition. Do not modify the appliance.
- Do not install or store appliance where it will be exposed to weather or temperatures below 40° F.
- Read and observe all important notices listed on the appliance and in the packaging.
- Never wash the filter with soapy water as the soap residue will seep into the filter and cannot be removed. Only rinse the filter with water.
- Use only PetSafe® brand authorized replacement filters. If unauthorized filters are used it may void the warranty.

SAVE THESE INSTRUCTIONS

Thank you for choosing the PetSafe® brand. You and your pet deserve a companionship that includes memorable moments and a shared understanding together. Our products and training tools enhance the relationship between pets and their owners. If you have any questions about our products or training your pet, please visit our website at www.petsafe.net or contact our Customer Care Center at **1-800-732-2677**.

PRODUCT WARRANTY

To get the most protection out of your warranty, please register your product within 30 days at www.petsafe.net. By registering and keeping your receipt, you will enjoy the product's full warranty and should you ever need to call the Customer Care Center, we will be able to help you faster. Most importantly, PetSafe® brand will never give or sell your valuable information to anyone. Complete warranty information is available online at www.petsafe.net.

TABLE OF CONTENTS

Components	4
Features	5
Key Definitions	5
OPERATING GUIDE	6
Fountain Disassembly & Cleaning	8
Pump Maintenance	10
Fountain Reassembly	11
The Fountain and Your Environment	12
General Tips	12
Troubleshooting	13
Replacement Parts and Accessories	14
Customer Care International	14
Terms of Use and Limitation of Liability	15
Warranty	15

Components

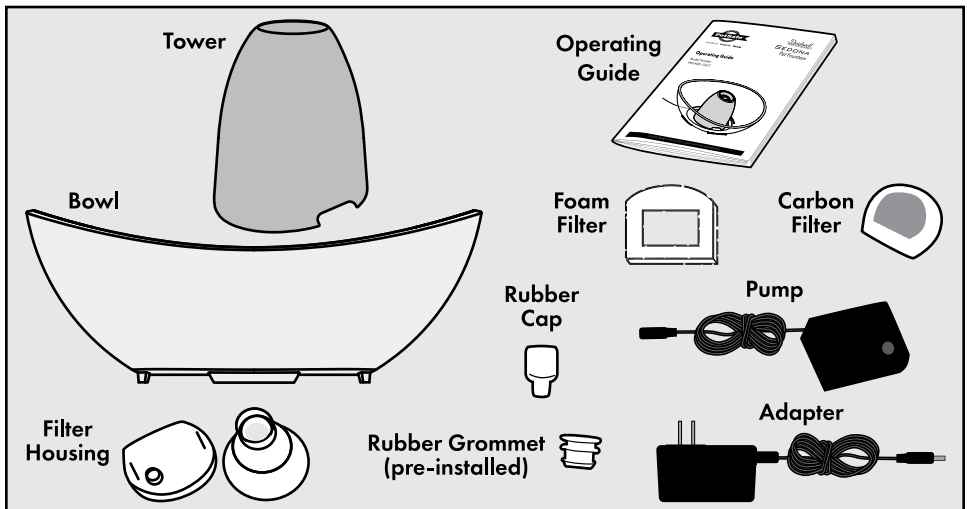

Features

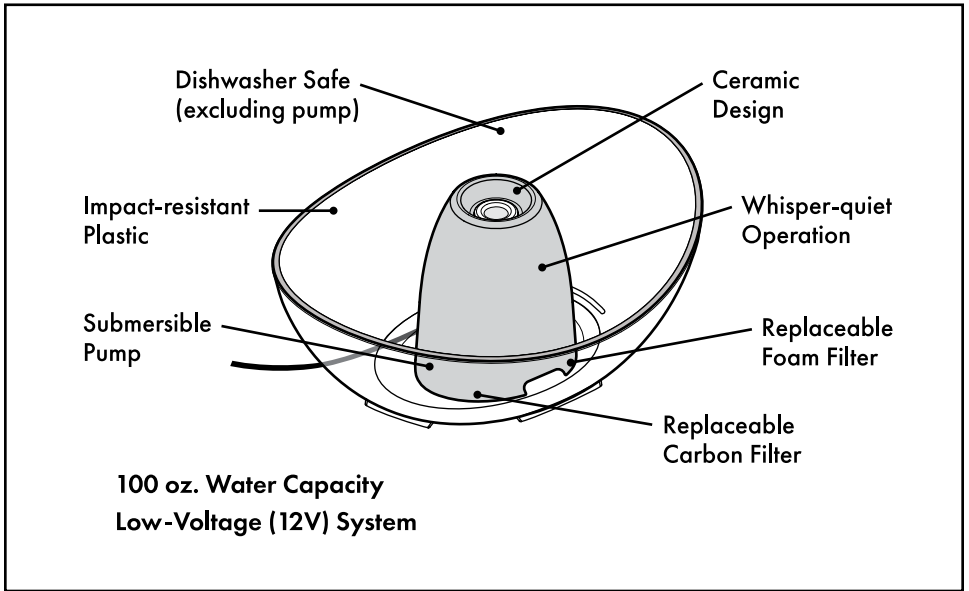

Key Definitions

Bowl: The plastic bowl is the foundation of the fountain. The bottom of the bowl features four indentations to run the electrical power cord through.

Tower: Water is pumped up through the ceramic tower to cycle through the carbon filter and out the top to create a waterfall into the bowl.

Filter Housing: The plastic filter housing consists of a lid and base that holds the carbon filter.

Rubber Grommet: The rubber grommet comes already installed in the top of the ceramic tower and forms a seal between the filter housing and the tower.

Rubber Cap: This rubber seal secures the electrical power cord to the inside of the bowl and prevents leaking.

Carbon Filter: The 3-layer filter is made with activated carbon derived from coconut shells. The carbon filter absorbs bad tastes and odors as the water passes through and helps keep the water tasting fresh and more appealing to pets.

Foam Filter: The foam filter collects any hair, debris, and pet food before they reach the pump. It is important to use the foam filter as it helps maintain proper pump function.

Pump: The small aquarium pump can be partially dismantled for cleaning. The pump is not dishwasher safe! Remove pump from the fountain before cleaning (see "Pump Maintenance" section for detailed instructions). The pump also features a removable in-line plug for easy attachment and removal.

OPERATING GUIDE

Step 1

Assemble Fountain

⚠ WARNING

- Do not use outdoors. Do not run dry. For indoor household use only.
- Do not pull on the electrical power cord to remove the plug from the electrical outlet.
- To unplug, grasp the plug, not the electrical power cord.

Note: *Rinse all fountain parts with warm water before operating the pet fountain. This will remove any dust or residue that remain in the system from the manufacturing process.*

1. Carefully remove all the fountain components from the packaging and set aside prior to assembly.
2. As with any electrical device, check the electrical power cord for any tears or damage before use.
3. Place the foam filter around the pump by inserting the pump into the foam filter from the top. Make sure the electrical power cord rests on top of the foam filter (**Fig.1**).

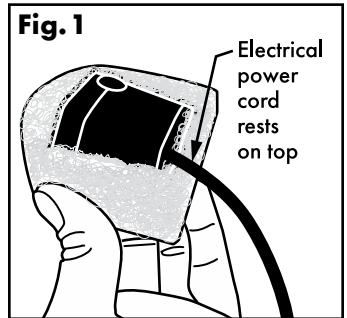

4. Take the bowl and place the pump inside the square indentation. (**Fig. 2**) With the bowl positioned so the raised post is to the right of the square, make sure the pump is positioned so that the pump outflow, the circular opening on the top of the pump, is positioned in the bottom left corner of the square (**Fig. 3**).

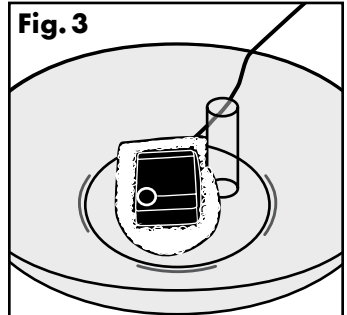
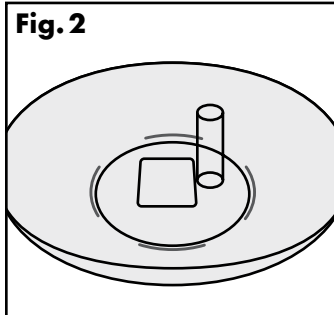

5. Press down on the pump to engage the suction cups. Once the pump is securely in place, feed the in-line plug of the electrical power cord over and through the raised post and out the notch on the base of the bowl (**Fig. 4**). There are four notches to choose from.

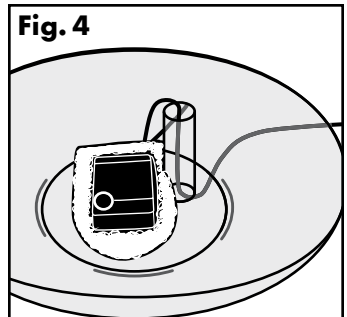

6. Remove the extra slack from the electrical power cord and insert the rubber cap into the raised post. Make sure the cord channel on the rubber cap is aligned with the electrical power cord, then insert your finger into the rubber cap and push all the way down (**Fig. 5**).

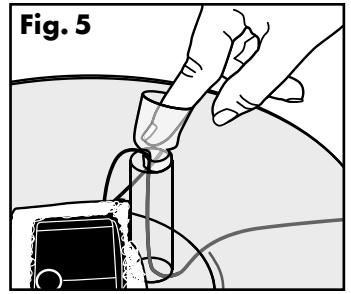

7. Fold the top of the rubber cap over the raised post to seal off the bowl (**Fig. 6**).

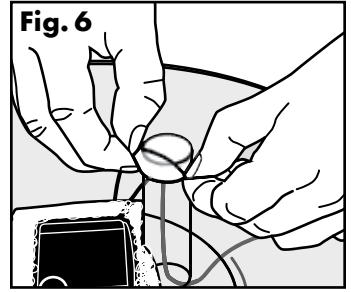

8. Rinse the carbon filter thoroughly under cool water before placing it into the filter housing. This will remove any loose carbon dust, which is harmless. A small amount of carbon dust may be released for the life of the filter. This is normal and is not harmful to your pet.

9. Detach the lid from the base of the filter housing. Once rinsed off, place the carbon filter inside the base of the filter housing with the larger side of the filter facing down. The filter will only fit inside the base of the filter housing one way. If it does not fit, flip it over (**Fig. 7**).

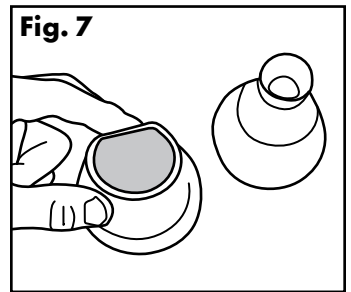

10. Attach the lid to the base of the filter housing. Press down until you hear it snap in place.

11. Attach the filter housing to the pump by inserting the round notch under the base into the circular opening on top of the pump (**Fig. 8**). The opening on top of the filter housing should be right next to the sealed raised post (**Fig. 9**).

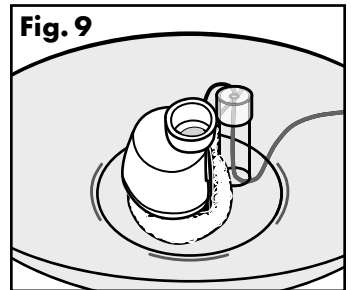
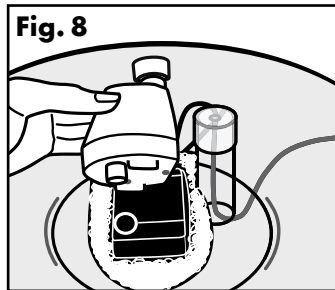

12. Place the ceramic tower inside the bowl. The rubber grommet will create a seal between the filter housing and the tower. Carefully lower the tower until it rests flat (**Fig. 10**).

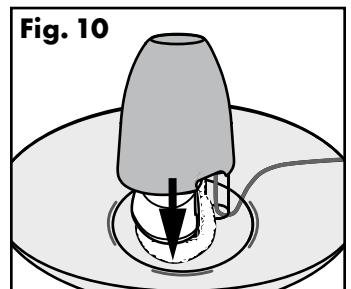

Step 2

Set Up and Add Water

1. Place the fountain in desired location. Do not pick up a full fountain by the tower piece. To properly pick up the fountain, use both hands and grip the sidewalls of the bowl and lift up.
2. Fill the fountain by pouring water directly into the bowl. Leave at least ½ inch of space between the water level and the rim of the bowl to help control spills and splashing. To protect your floor always use a protective mat, such as a towel or water resistant placemat. This will help protect your floor from splashing or spills caused by your pet.
3. Before you plug in the fountain, make sure the electrical power cord, the adapter and your hands are completely dry. Connect the in-line plug and make sure no silver is showing, then plug the adapter into a standard electrical wall outlet.
4. Add water to the bowl as needed. Never let the water level fall below 1 inch from the base of the bowl or you might risk pump failure. Replacement pumps are sold separately by calling the Customer Care Center at 1-800-732-2677 or visit www.petsafe.net.

Fountain Disassembly and Cleaning

NOTICE

- Fountain must be cleaned to continue working normally.
- Never wash the filters with soapy water, as the soap residue will seep into the filters and cannot be removed. Only rinse the filters with water.
- Use only PetSafe® brand authorized replacement filters. If unauthorized filters are used it may void the warranty.

Note:

Use a soft cloth or sponge to prevent scratching the bowl.

CARBON FILTER: Replace carbon filter every two to four weeks.

- Always rinse the carbon filter prior to use.
- A small amount of carbon dust may be released for the life of the filter, this is normal and is not harmful to your pet.
- Replace filters more frequently when using the fountain for multiple pets or pets that produce a lot of saliva.

FOAM FILTER: Replace the foam filter every one to two months.

- If you do not intend to replace the filter at the time of cleaning, rinse the foam filter thoroughly with fresh water.

Filter subscriptions now available! Get fountain filters automatically and conveniently delivered right to your door when you need them. Free shipping and 5% discount included. Visit www.petsafe.net to sign up or call our Customer Care Center at **1-866-738-4379**.

PET FOUNTAIN: Clean the fountain once a week.

1. Unplug the fountain and disconnect the in-line plug (Fig. 11).
2. Carefully lift the tower and allow the water to slowly pour back into the bowl. Once all the water has been emptied into the bowl, set the tower aside for cleaning (Fig. 12).
3. Take the tower and turn upside down to remove the rubber grommet. Grab the rubber grommet from inside and pull straight out, set aside for cleaning (Fig. 13).
4. Remove the filter housing from the pump by lifting straight up (Fig. 14).
5. Open the filter housing and remove the carbon filter from inside and dispose. Set the lid and base of the filter housing aside for cleaning.
6. Remove the rubber cap affixed to the raised post by inserting a finger under the lip and pull straight up to remove (Fig. 15).
7. While securely holding the electrical power cord and the bottom of the bowl with both hands, pour out the remaining water inside the bowl into a sink.
8. With the in-line plug disconnected and water removed, grab the pump and lift straight up to disengage the suction cups. Continue pulling the pump's electrical power cord up and out through the raised post in the center of the bowl. Once the pump is completely removed from the bowl, separate the foam filter and set aside for proper cleaning.
9. Once the fountain is completely disassembled, you will have: the bowl, tower, two rubber pieces, the filter housing, foam filter and the pump.
10. Rinse the foam filter with water only or replace it with a new one.
11. See the "Pump Maintenance" section of this Operating Guide for detailed instructions on how to properly clean your pump. **DO NOT PLACE PUMP IN DISHWASHER!**
12. Hand wash all other fountain parts with warm water and soap. Be sure to rinse thoroughly with fresh water. You can also put the fountain in the top rack of the dishwasher. If possible, it is recommended that you turn down the heat of the water inside the dishwasher.

Fig. 11

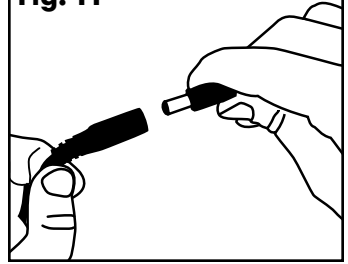

Fig. 12

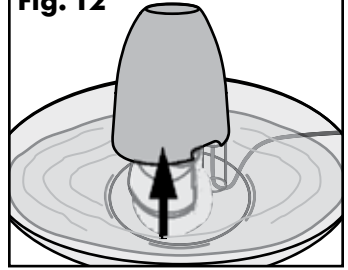

Fig. 13

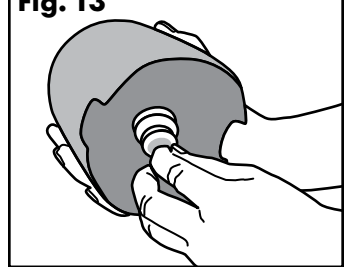

Fig. 14

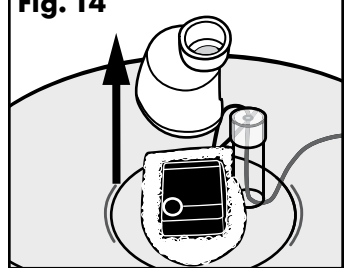
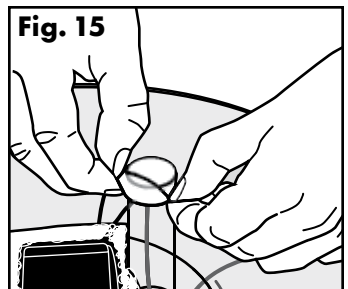
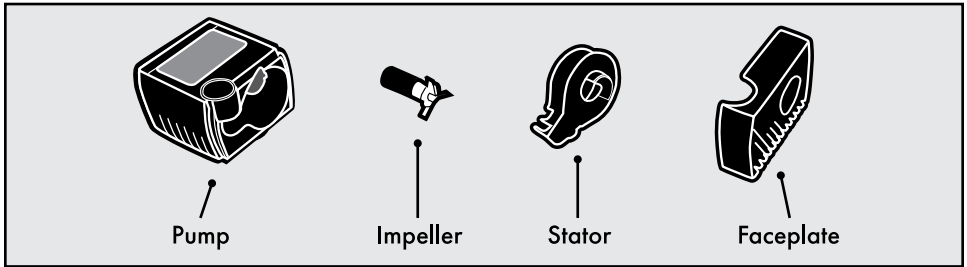

Fig. 15



Pump Maintenance

Note: *Cleaning the pump is essential to the longevity of the fountain, as well as the cleanliness of the water. Clean the pump every two weeks. Warranty may be voided if the pump's motor is not cleaned regularly.*



1. Remove pump from the fountain as explained in the "Fountain Disassembly and Cleaning" section.
2. Remove the faceplate by using your thumb and forefinger to gently squeeze on both sides of the faceplate and pull off. It may be necessary to insert a fingernail into the seam of the faceplate to pry it off (**Fig. 16**).
3. Next, remove the stator by placing your fingernail underneath the small lip located on the narrow side of teardrop-shaped stator (**Fig. 17**) and pull out to remove.
4. Once the stator is removed, remove the impeller (white, 3-bladed propeller). The impeller is held in place by a magnet, simply use a fingernail to get underneath the blade and lift out (**Fig. 18**).
5. Once the pump is completely disassembled, you can clean the parts with warm water and soap. Use a cotton swab or the "motor brush" from the Drinkwell® Cleaning Kit to clean inside the pump's motor cavity and remove any build-up (**Fig. 19**). For added disinfecting and hard water removal, clean the pump's motor with a diluted white vinegar solution (20% white vinegar and 80% water).
6. Once the parts are clean you can reassemble the pump for use.
 - a) Replace the impeller.
 - b) Replace the stator.
 - c) Replace the faceplate.

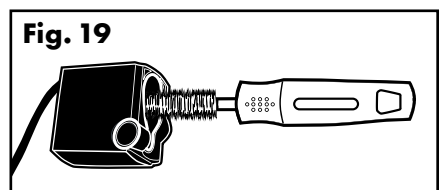
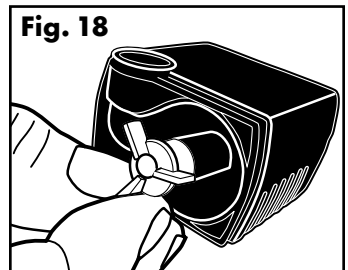
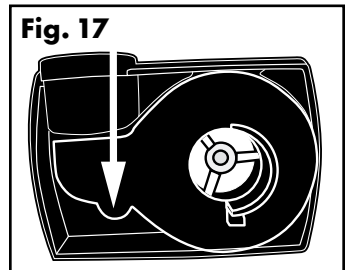
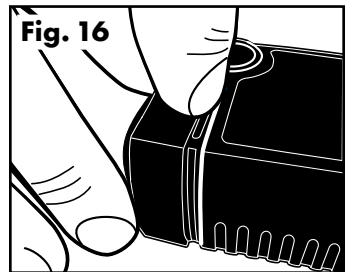

Fountain Reassembly

1. Place the foam filter around the pump and make sure the electrical power cord rests on top. **(Fig. 20)**.
2. Take the bowl and place the pump inside the square indentation. With the bowl positioned so the raised post is to the right of the square, make sure the pump is positioned so that the pump outflow, the circular opening on the top of the pump, is positioned in the bottom left corner of the square **(Fig. 21)**.
3. Press down on the pump to engage the suction cups. Once the pump is securely in place, feed the in-line plug of the electrical power cord over and through the raised post and out the notch on the base of the bowl. **(Fig. 22)** There are four notches to choose from.
4. Remove the extra slack from the electrical power cord and insert the rubber cap into the raised post. Make sure the cord channel on the rubber cap is aligned with the electrical power cord, then insert your finger into the rubber cap and push all the way down.
5. Fold the top of the rubber cap over the raised post to seal off the bowl **(Fig. 23)**.
6. Rinse a new carbon filter thoroughly under cool water before placing it into the filter housing. This will remove any loose and excess carbon dust, which is harmless.
7. Detach the lid from the base of the filter housing. Once rinsed off, place the carbon filter inside the base of the filter housing with the larger side of the filter facing down. The filter will only fit inside the base of the filter housing one way. If it does not fit, flip it over.
8. Attach the lid to the base of the filter housing. Press down until you hear it snap in place.
9. Attach the filter housing to the pump by inserting the round notch under the base into the circular opening on top of the pump. The opening on top of the filter housing should be right next to the sealed raised post **(Fig. 24)**.
10. Place the ceramic tower inside the bowl. The rubber grommet will create a seal between the filter housing and the tower. Carefully lower the tower until it rests flat **(Fig. 25, see next page)**.

Fig. 20

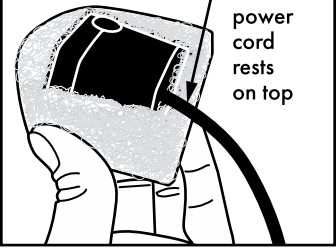

Fig. 21

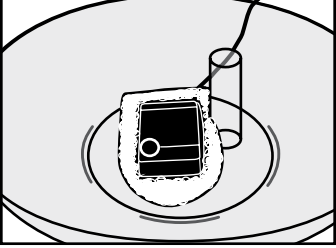

Fig. 22

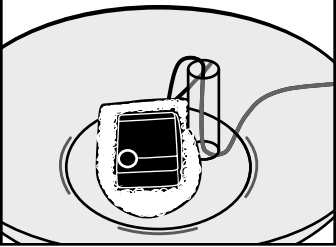

Fig. 23

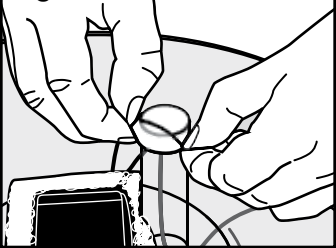
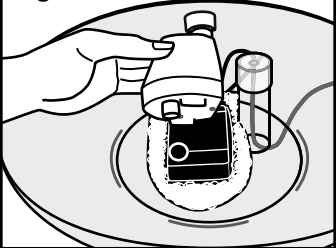
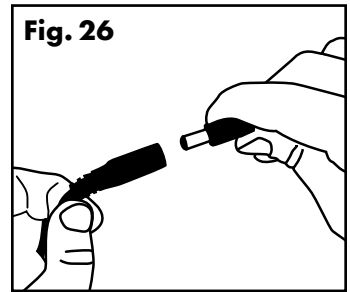
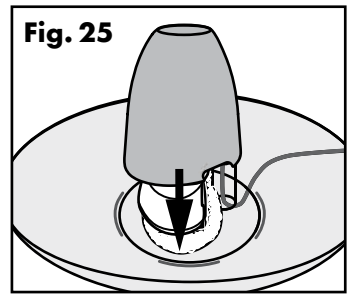

Fig. 24



11. Place the fountain in desired location. Do not pick up a full fountain by the tower piece. To properly pick up the fountain, use both hands and grip the sidewalls of the bowl and lift up.
12. Fill the fountain by pouring water directly into the bowl. Leave at least $\frac{1}{2}$ inch of space between the water level and the rim of the bowl to help control spills and splashing. To protect your floor always use a protective mat, such as a towel or water resistant placemat. This will help protect your floor from splashing or spills caused by your pet.
13. Before you plug in the fountain, make sure the electrical power cord, the adapter and your hands are completely dry. Connect the in-line plug and make sure no silver is showing, (**Fig. 26**) then plug the adapter into a standard electrical wall outlet.



The Fountain and Your Environment

If you live in a humid environment and have problems with mold or algae, soak all fountain parts in a diluted vinegar solution (20% white vinegar and 80% water) for 10 minutes after regular cleaning. Also, pour the diluted vinegar solution into the pump's motor cavity. If you have hard water, small white mineral deposits may form on or inside the pump. This can eventually prevent the impeller from turning properly. To avoid replacement or damage to the pump, please take the following precautions:

- Clean the pump more frequently.
- Clean the pump with a diluted vinegar solution weekly.
- Use bottled water instead of tap water.

General Tips

- When being introduced to the fountain, your pet may be cautious of this new and unusual object. After beginning operation of your fountain, simply allow your pet to adjust at his or her own pace. Some pets may take several days or longer to begin use, while others will start right away.
- Your pet may prefer that the fountain be placed away from their normal feeding area. Try placing it in another location, such as a different area of the kitchen or in a bathroom or utility room.
- Add ice cubes to the bowl for refreshing, ice-cold running water.

Troubleshooting

The answers to these questions should help you solve most problems you may have with the pet fountain. If they do not, please contact our Customer Care Center at **1-800-732-2677**.

TROUBLESHOOTING

PROBLEM	SOLUTION
Pump is not working or the water is not flowing as much as it used to.	<ul style="list-style-type: none">• Never let the water in the bowl get below the minimum fill level. This can cause the pump to overheat and stop functioning.• When refilling the bowl, make sure to add water before turning the fountain on.• Lack of regular cleaning may result in the pump becoming clogged with pet hair and food debris. The pump must be cleaned every 2-4 weeks to ensure proper function.• A video detailing how to properly clean the pump is available on our website at www.petsafe.net.• Fill the fountain with water up to the max fill line.
Fountain is loud.	<ul style="list-style-type: none">• A low humming noise is normal, but it should not be loud. Check the water level. If water level is too low then the pump will have to work harder causing it to be louder than normal.• Unplug the fountain for 15 seconds. If the noise does not stop when plugged back in, it's possible that some debris is caught on the impeller. Remove the pump and clean the impeller. Try rubbing a small amount of vegetable oil onto the magnetic pin with a cotton swab to lubricate the impeller.
There are black particles in the bowl.	<ul style="list-style-type: none">• This is loose granulated carbon dust from the filter and is completely harmless for your pet to drink. Rinse the filter in cold water before placing it in the fountain to prevent this.
The fountain feels slimy.	<ul style="list-style-type: none">• If you have multiple pets or dogs using the fountain, the slimy feeling may be caused by your pet's saliva. Change the water and clean your fountain more frequently to prevent this.• Make sure the fountain parts are rinsed thoroughly after cleaning the fountain. Soap residue may cause the sliminess.
The adapter is warm to the touch.	<ul style="list-style-type: none">• Unplug the fountain and plug it into a surge protector.

The fountain is leaking.	<ul style="list-style-type: none"> Sometimes water around the fountain is caused by pets drinking. Some pets are prone to spilling. Watch your pet when he drinks to see if this is the cause. If it is, you can purchase a fountain mat or other water-resistant mat to place under the fountain.
The fountain seems dirty even after cleaning.	<ul style="list-style-type: none"> If there is a white chalky substance in the fountain, your fountain may have a mineral deposit build-up from hard water. To remove these deposits, clean the fountain parts with a 80% water and 20% vinegar solution. Rinse all parts thoroughly afterwards. Use filtered or purified water instead of hard tap water to prevent this.

Replacement Parts and Accessories

Replacement parts or accessories for your fountain can be purchased by visiting www.petsafe.net or by contacting our Customer Care Center at **1-800-732-2677**.

Filter subscriptions now available! Get fountain filters automatically and conveniently delivered right to your door when you need them. Free shipping and 5% discount included. Visit www.petsafe.net to sign up or call our Customer Care Center at 1-866-738-4379.

Part Description	Replacement Part Number
Drinkwell® Carbon Replacement Filters, 4-Pack	PAC00-13906
Drinkwell® Foam Replacement Filters, 2-Pack	PAC00-13711
Drinkwell® Replacement Pump	PAC00-13206
Drinkwell® Replacement Filter Housing	PAC00-13908

Customer Care International

USA & Canada - Tel: 800-732-2677

Monday - Friday 8 AM - 8 PM / Saturday 9 AM - 5 PM

Australia - Tel: 1800 786 608

Monday - Friday 8:30 AM - 5 PM

New Zealand - Tel: 0800 543 054

Monday - Friday 10:30 AM - 7 PM

Terms of Use and Limitation of Liability

1. Terms of Use

This product is offered to you conditioned upon your acceptance without modifications of the terms, conditions and notices contained herein. Use of this product implies acceptance of all such terms, conditions and notices.

2. Proper Use

Proper use includes reviewing the entire Guide provided with your Product and any safety precautions listed.

3. No Unlawful or Prohibited Use

This Product is designed for use with pets only. This device is not intended to harm, injure or provoke. Using this Product in a way that is not intended could result in violation of Federal, State or local laws.

4. Limitation of Liability

In no event shall Radio Systems Corporation be liable for any direct, indirect, punitive, incidental, special or consequential damages, or any damages whatsoever arising out of or connected with the use or misuse of this Product. Buyer assumes all risks and liability from the use of this Product.

5. Modification of Terms and Conditions

Radio Systems Corporation reserves the right to change the terms, conditions and notices under which this Product is offered.

Warranty

Two Year Non-Transferrable Limited Warranty

This Product has the benefit of a limited manufacturer's warranty. Complete details of the warranty applicable to this Product and its terms can be found at www.petsafe.net and/or are available by contacting your local Customer Care Center.

Europe – Radio Systems PetSafe Europe Ltd., 2nd Floor, Elgee Building, Market Square, Dundalk, Co. Louth, Ireland

Canada – Radio Systems Corporation, 10427 PetSafe Way, Knoxville, TN 37932 USA

Australia/New Zealand – In compliance with the Australian Consumer Law, Warranties Against Defects, effective January 1, 2012, warranty details of this Product are as follows: Radio Systems Australia Pty Ltd. (hereinafter referred to as "Radio Systems") warrants to the original retail purchaser, and not any other purchaser or subsequent owner, that its Product, when subject to normal and proper residential use, will be free from defects in material or workmanship for a period of two (2) years from the purchase date. An "original retail consumer purchaser" is a person or entity who originally purchases the Product, or a gift recipient of a new Product that is unopened and in its original packaging. When serviced by Radio Systems Customer Service, Radio Systems covers labour and parts for the first two years of ownership; after the first two years, a service or upgrade charge will apply relative to replacement of the Product with new or refurbished items at Radio Systems' sole discretion.

The limited warranty is non-transferrable and shall automatically terminate if the original retail consumer purchaser resells the Radio Systems Product or transfers the property on which the Radio Systems Product is installed. This Limited Warranty excludes accidental damage due to dog chews; lightning damage; or neglect, alteration, and misuse.

Consumers who purchase products outside of Australia, New Zealand, or from an unauthorised dealer will need to return the Product to the original place of purchase for any warranty issues.

Please note that Radio Systems does not provide refunds, replacements, or upgrades for change of mind, or for any other reason outside of these Warranty terms.

Claims Procedure: Any claim made under this Warranty should be made directly to Radio Systems Australia Pty Ltd Customer Care Centre at:

Radio Systems Australia Pty. Ltd.

PO Box 7266, Gold Coast Mail Centre QLD 9726, Australia

Australia Residents: 1800 786 608

New Zealand Residents: 0800 543 054

Email: info@petsafeaustralia.com.au

To file a claim, a proof of purchase must be provided. Without a proof of purchase, Radio Systems will not repair or replace faulty components. Radio Systems requests the Consumer to contact the Radio Systems Customer Care Centre to obtain a Warranty Return number, prior to sending the Product. Failure to do so may delay in the repair or replacement of the Product.

If the Product is deemed to be faulty within 30 days from date of original purchase, Radio Systems will organise for a replacement to be sent in advance of returning the faulty Product. A Post Bag will be included with the replacement Product for the return of the faulty Product. The Product must be returned within 7 days of receiving the replacement. If the Product is deemed to be faulty after 30 days from the date of original purchase, the consumer will be required to return the Product to Radio Systems at the consumer's own expense. Radio Systems will test and replace the faulty unit or its components and return to the consumer free of charge, provided the Product is within its said warranty period. This warranty is in addition to other rights and remedies available to you under the law. Radio Systems goods come with guarantees that cannot be excluded under the Australia Consumer Law. You are entitled to a replacement or refund for a major failure and for compensation for any other reasonably foreseeable loss or damage. You are also entitled to have the good repaired or replaced if the goods fail to be of acceptable quality and the failure does not amount to a major failure.

Should you have any queries or require any further information, please contact our Customer Care Centre on 1800 786 608 (Australia) or 0800 543 054 (New Zealand).

Radio Systems Corporation
10427 PetSafe Way
Knoxville, TN 37932
1-800-732-2677
www.petsafe.net

©2015 Radio Systems Corporation

400-1867